

# SERPAC H-67, AC

Electronics Enclosures

**NOTES:**

1. WHEN MACHINE OR I PLATES MODIFICATIONS ARE REQUIRED, USE THE CENTER OF THE BOX TO DIMENSION.

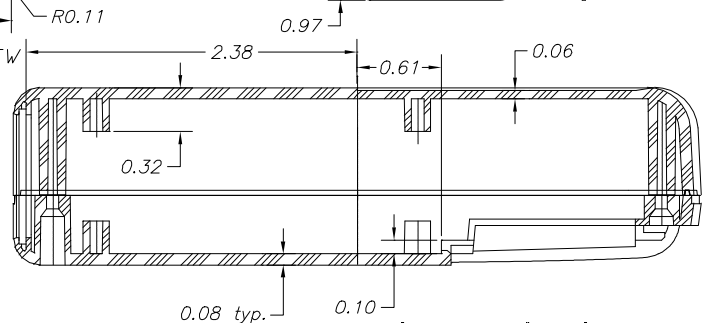
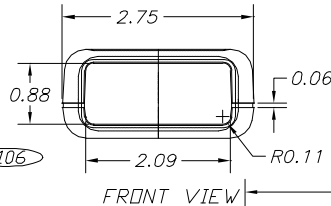
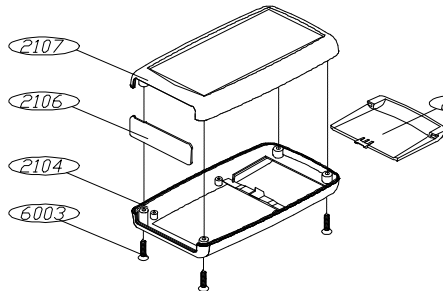
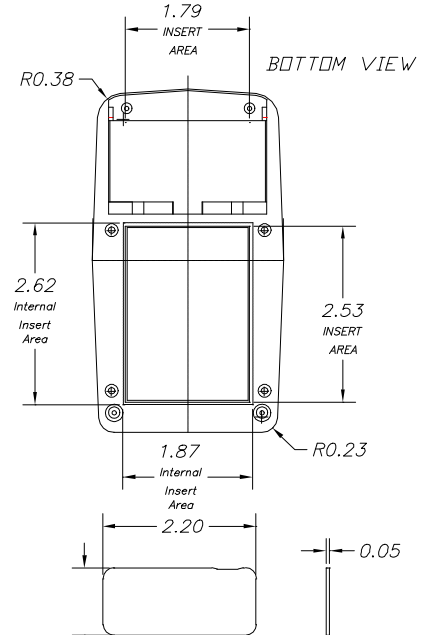
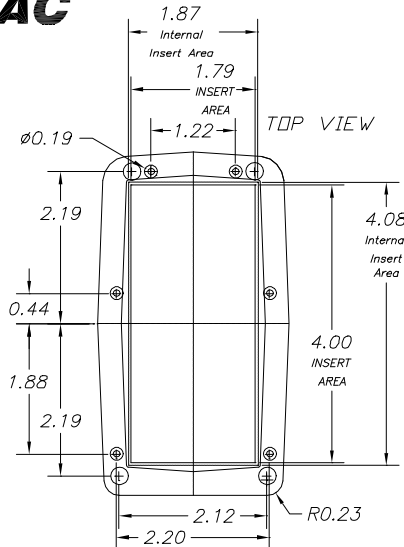
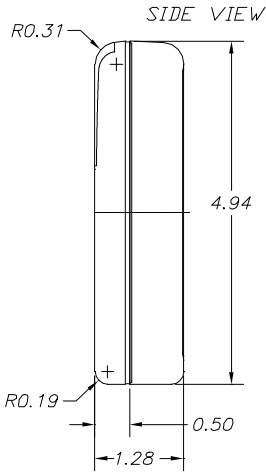

10-30-98

ALL DIMENSIONS ±0.10

PART NO.	DESCRIPTION	PART NO.	ACCESSORIES
2100	PLASTIC TOP	2108CL	CLEAR PANEL
2108	PLASTIC END PANEL	2108IR	INFRARED PANEL
2102	PLASTIC BOTTOM	2108R	TRANSPARENT RED PANEL
6003	SCREW		
2106	PLASTIC BATTERY COVER		